

SPM01

Smart Energy Sensor / Monitor with Wireless-communication for 1P+N System

User Manual

*Make energy monitoring easy
for buildings, infrastructures and industries*

- ✧ Energy metering accurately
- ✧ Alarm reporting timely
- ✧ Automation setting smartly

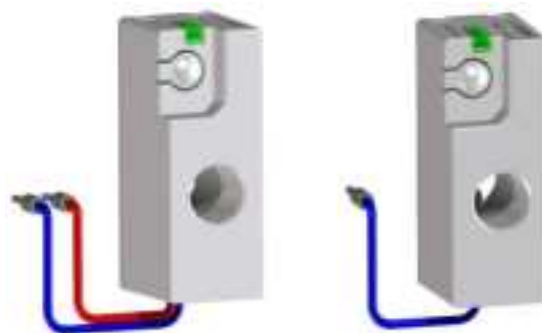

SPM01 smart energy monitor - also named as smart energy sensor- is an electrical monitoring device with wireless communication. It works like a smart electrical monitoring accessory for protective and control devices, such as circuit breakers and modular contactors.

SPM01 has the following main characteristics

- Flexibly installed above/below protection or control devices requiring no space at Din rail
- Large aperture supporting 16mm² cable through
- Real-time measurement of Voltage, Current and Power
- Bi-directional energy measurement and forward active energy tolerance within 1%
- Both wireless and wire communication variants available for EMS/ BMS¹⁾ integration
- Useful smart features including balance calculation, chart analysis, alarm messaging, scene setting, etc.

Typical applications for SPM02

- Factory energy monitoring
- Home energy monitoring²⁾
- Café, restaurant and shop energy monitoring
- Office energy monitoring
- Hotel and student dorm energy monitoring / metering³⁾
- Rental properties energy monitoring / metering³⁾
- Energy monitoring for commercial air conditioning system
- Energy monitoring for commercial lightning system

1) EMS: Energy Management System; BMS: Building Management System

2) In addition to whole-home energy monitoring when being installed at the main circuit (incoming line), the real-time measurement of bi-directional current flow can provide input for dynamic load balancing with EV charger and PV power generation optimization

3) Metering certificate for billing purpose can be extended depending on the country/region regulations

SPM01

Smart Energy Sensor / Monitor with Wireless-communication for 1P+N System

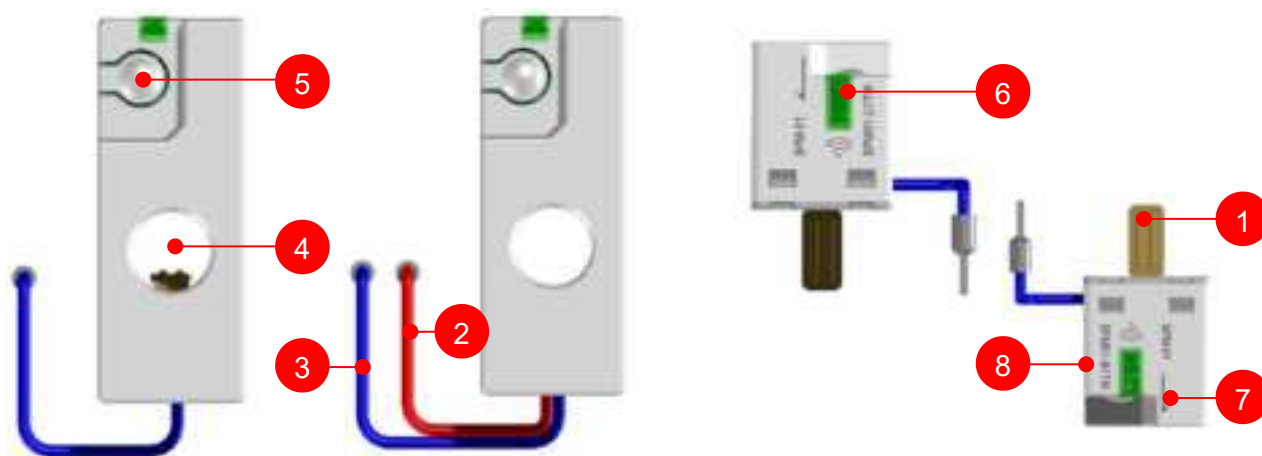

#	Element	Description
(1)	Terminal plate for L	Insert to protective device terminal box for power supply from Line ¹⁾
(2)	Cable for L	Connect to power supply from Line
(3)	Cable for N	Connect to power supply from Neutral
(4)	Through-hole	Let the measuring cable L going through the through-hole ²⁾ Pay attention for positive current flow aligning with the arrow direction (7)
(5)	Reset button	Reset button Press the button 3~5 seconds to enter the pairing mode ³⁾
(6)	LED	Status indication <ul style="list-style-type: none"> ■ ON, normal using, connect to cloud █ Flashing with 2Hz, pairing mode █ Flashing with 0.5Hz, paired, searching for cloud █ Flashing with 0.25Hz, self-checking failed⁴⁾ █ Flashing with 1Hz, wireless communication failed⁵⁾
(7)	Current flow direction	Positive current flow direction for installation
(8)	Order number	Refer to page 4 and 5 for more details

Remark:

- 1) Hanging-on-cable variants are recommended, if users don't know mount-on-MCB" variant compatibility.
- 2) Do not put both line cable and neutral cable going through the hole
- 3) Press the reset button 3~5 seconds till the LED is quickly flashing to enter the pairing mode.
Same function as Remove Device in APP.
- 4) Irreversible failure due to failed self-checking. Device needs to be replaced.
- 5) Input voltage is too low to ensure communication module inside working properly.

SPM01

Smart Energy Sensor / Monitor with Wireless-communication for 1P+N System

#	Technical specification	
101	Rated operating voltage U_n	110...240 VAC, 50/60 Hz
102	Basic current I_b	10 A
103	Starting current I_{st}	50 mA
104	Max current I_{max}	63 A
105	Over-voltage category	III
106	Rated insulating voltage U_i	250V
107	Rated impulse withstand voltage U_{imp}	4kV
108	Pollution degree	3
109	Protection degree	IP20
110	Reference standard for measurement tolerance: IEC 61557-12	Voltage: Class 0.5 Current: Class 1 Active power: Class 1 Forward active energy: Class 1
111	Power consumption	Normal using: 0.5 Watt Pairing mode: 1 Watt
112	Rated operating temperature	-25...60 °C
113	Size: Height x Width x Depth	46.8mm x 17.8mm x 21.3mm
114	Reference standard:	IEC 61557-12 IEC 61326-1 ETSI EN 300 328 ETSI EN 301 489-1 ETSI EN 301 489-17

SPM01

Smart Energy Sensor / Monitor with Wireless-communication for 1P+N System

Product part 1 – Integration to Tuya Smart cloud¹⁾

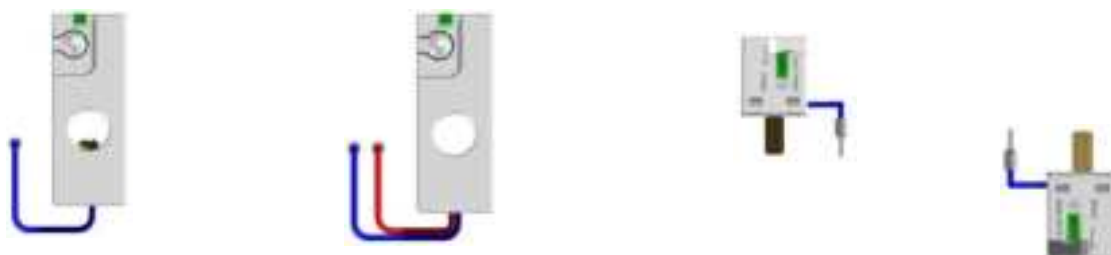

#	Ordering number		Description
1	SPM01-D1TW		Mounted on MCB ²⁾ (Downstream installation), 18mm, WiFi, 1P+N, Tuya Smart cloud integration
2	SPM01-U1TW		Mounted on MCB ²⁾ (Upstream installation), 18mm, WiFi, 1P+N, Tuya Smart cloud integration
3	SPM01-D1TZ		Mounted on MCB ²⁾ (Downstream installation), 18mm, Zigbee, 1P+N, Tuya Smart Zigbee gateway integration
4	SPM01-U1TZ		Mounted on MCB ²⁾ (Upstream installation), 18mm, Zigbee, 1P+N, Tuya Smart Zigbee gateway integration
5	SPM01-D2TW		Hanging on cable (Downstream installation), 18mm, WiFi, 1P+N, Tuya Smart cloud integration
6	SPM01-U2TW		Hanging on cable (Upstream installation), 18mm, WiFi, 1P+N, Tuya Smart cloud integration
7	SPM01-D2TZ		Hanging on cable (Downstream installation), 18mm, Zigbee, 1P+N, Tuya Smart Zigbee gateway integration
8	SPM01-U2TZ		Hanging on cable (Upstream installation), 18mm, Zigbee, 1P+N, Tuya Smart Zigbee gateway integration

Remark:

1) The Wifi and Zigbee modules from Tuya Smart use its proprietary protocol, which limits the devices' direct cloud integration to the Tuya Smart cloud. Tuya Integration at Home Assistant OS and API to Tuya Smart cloud can be used to access the device indirectly. For customer-specific cloud integration or local smart home OS integration, please use the products with Zigbee 3.0 standard meter cluster/attributes or contact us for other solutions.

2) If users are not sure if the 'mounted-on-MCB' variants fit for the protection/control devices, 'Hanging-on-cable' variants are recommended.

SPM01

Smart Energy Sensor / Monitor with Wireless-communication for 1P+N System

Product part 2 – Zigbee 3.0 standard meter cluster/attributes supporting ZHA/Zigbee2Mqtt integration

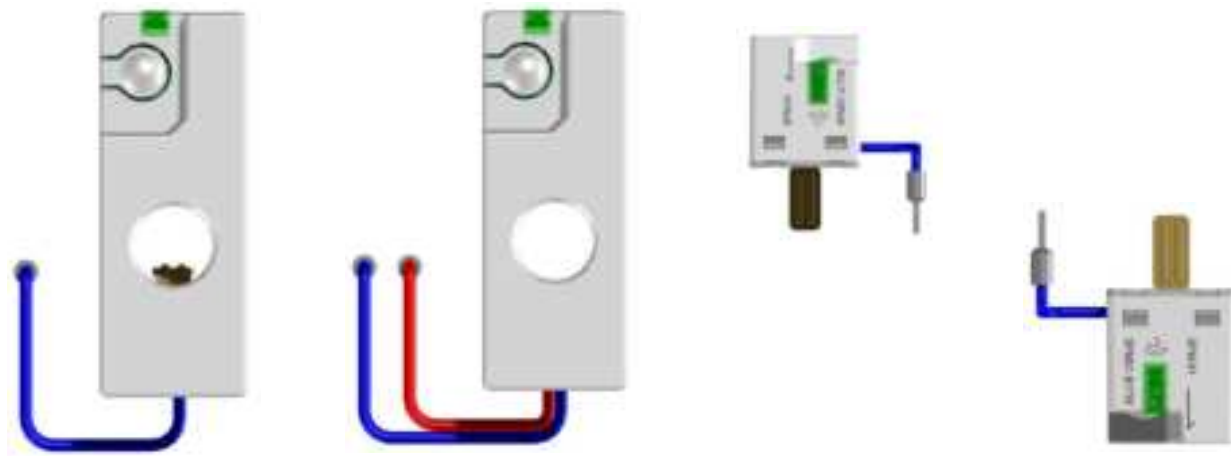

#	Ordering number		Description
1	SPM01-D1SZ		Mounted on MCB ²⁾ (Downstream installation), 18mm, Zigbee, 1P+N, Universal Zigbee coordinator integration
2	SPM01-U1SZ		Mounted on MCB ²⁾ (Upstream installation), 18mm, Zigbee, 1P+N, Universal Zigbee coordinator integration
3	SPM01-D2SZ		Hanging on cable (Downstream installation), 18mm, Zigbee, 1P+N, Universal Zigbee coordinator integration
4	SPM01-U2SZ		Hanging on cable (Upstream installation), 18mm, Zigbee, 1P+N, Universal Zigbee coordinator integration

Remark:

1) The devices listed above use Zigbee 3.0 standard meter cluster/attributes. Thus, the devices can be identified by universal Zigbee coordinators for ZHA/Zigbee2Qtt integration.

2) If users are not sure if the 'mounted-on-MCB' variants fit for the protection/control devices, 'Hanging-on-cable' variants are recommended.

SPM01

Smart Energy Sensor / Monitor with Wireless-communication for 1P+N System

Please note before starting Installation

- **SPM01 must only be installed and maintained by qualified professionals.** Qualified professionals refer to those who have the skills, license and knowledge related to the manufacture, operation and installation of electrical equipment. They are trained to detect and avoid risks.
- SPM01 should not be installed if, while unpacking, any damage is observed.
- SPM01 must be installed inside electrical panels or switchboards, behind a door or plate, so that they are inaccessible for unauthorized persons. The electric panels must meet the requirements of the applicable standards (IEC 61439-1) and installed in compliance with current installation and safety rules (IEC 61140).
- All relevant local, regional, and national regulations must be respected while installing and using SPM01.
- SPM01 manufacturer declines any responsibility in the event that SPM01 equipment is associated with equipment that is not listed in the latest document of selection guide for product compatibility.
- SPM01 manufacturer is not liable in case the instructions mentioned in this document and other referred documents are not respected.



HAZARD OF ELECTRIC SHOCK, EXPLOSION OR ARC FLASH

- Turn off all power supply sources before installing and during maintenance of this equipment.
- Do not use a SPM01 product for voltage testing purposes. A Voltage Tester must be used instead.

Failure to follow these instructions can result in death, serious injury, or equipment damage.



FIRE HAZARD

- SPM01 must be associated with an easily accessible upstream protection and circuit-breaker system.
- The end of cable for L and N at SPM01 must be adjusted to the according equipment and device. Such an adjustment can only be handled by qualified professionals.

Failure to follow these instructions can result in death, serious injury, or equipment damage.



RISK OF DAMAGING SPM01 Sensor

- Comply with the phase and the neutral position. (Red=Phase, Blue=Neutral)
- Disconnect SPM01 before performing the dielectric withstand test.
- SPM01 can only be installed upstream if associated with contactors, frequency converter or motor starters.
- Limit the insulation measurements up to 500 V DC.

Failure to follow these instructions can result in equipment damage.

SPM01

Smart Energy Sensor / Monitor with Wireless-communication for 1P+N System

Downstream Installation Scheme

(SPM01-D1TW / SPM01-D1TZ / SPM01-D2TW / SPM01-D2TZ / SPM01-D1SZ / SPM01-D2SZ)

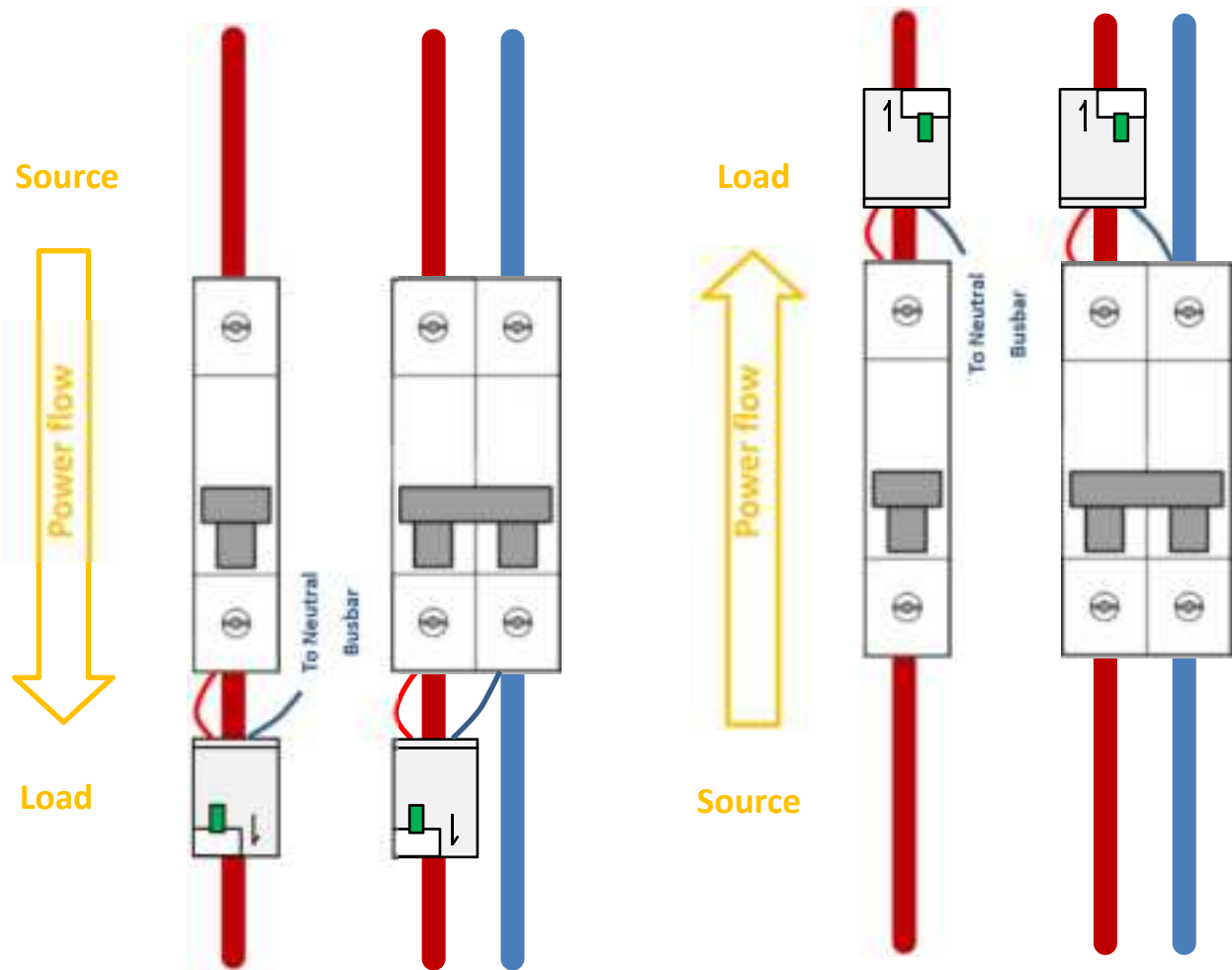

Note: SPM01 can be damaged, if it is installed downstream of switching devices – such as a contactor, frequency converter or motor starters.

SPM01

Smart Energy Sensor / Monitor with Wireless-communication for 1P+N System

Upstream Installation Scheme

(SPM01-U1TW / SPM01-U1TZ / SPM01-U2TW / SPM01-U2TZ / SPM01-U1SZ / SPM01-U2SZ)

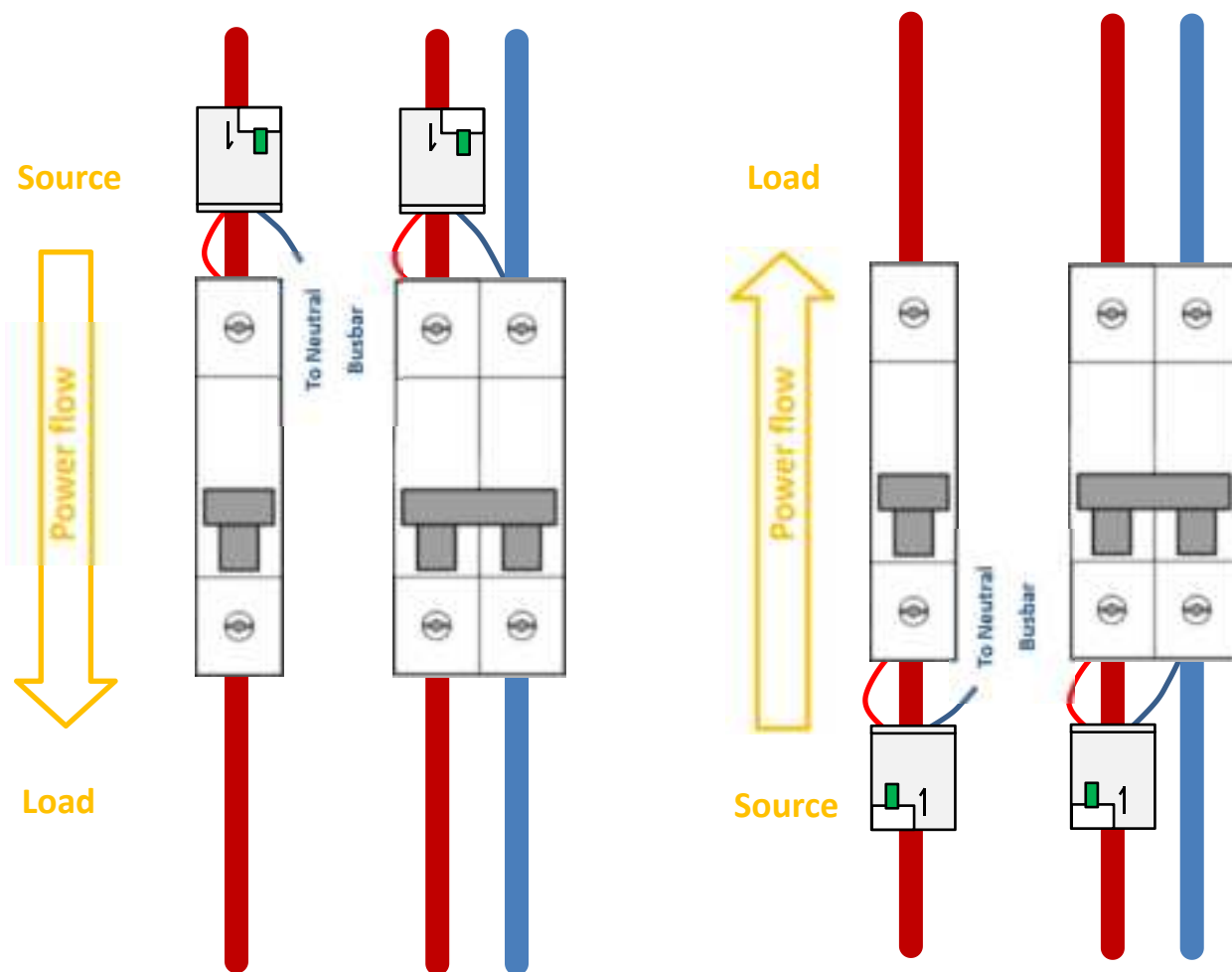

SPM01

Smart Energy Sensor / Monitor with Wireless-communication for 1P+N System

Dimension: Unit: mm

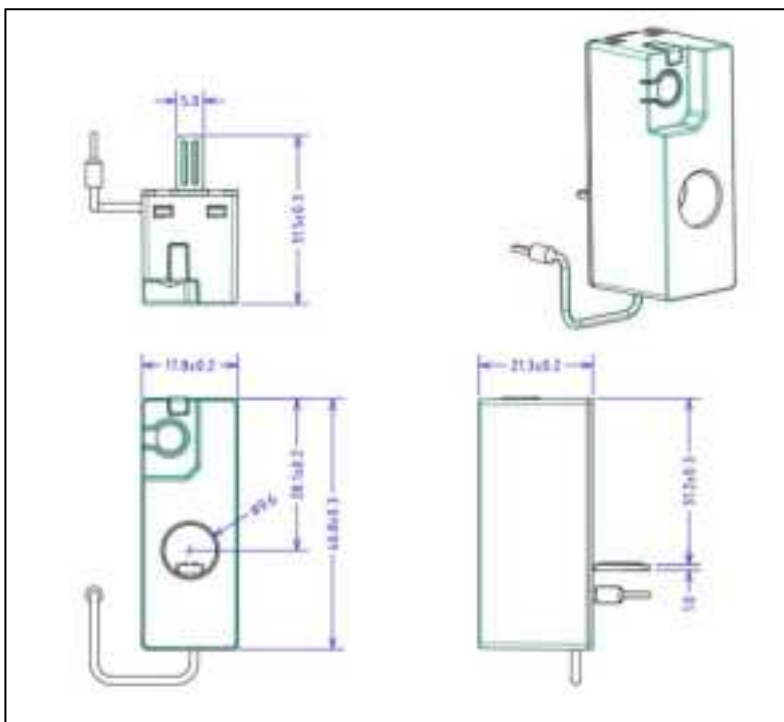
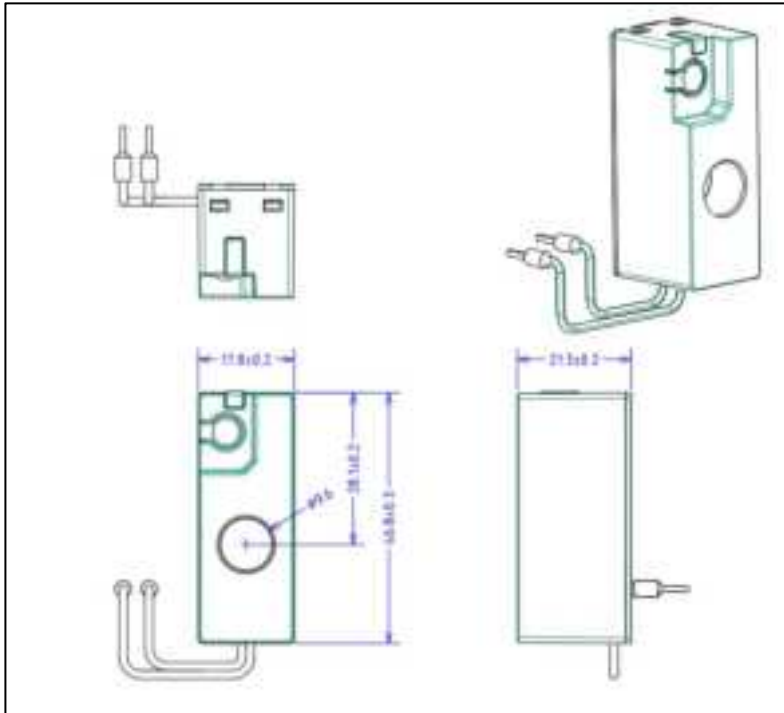

SPM01

Smart Energy Sensor / Monitor with Wireless-communication for 1P+N System

User interface example – home page (Smart Life APP)



- 1 Device information¹⁾
Click edit mark for modification
- 2 Total forward active energy
Pay attention to current flow direction
- 3 Current daily energy consumption chart
Click to view more details
- 4 Energy consumption at current hour
Click to view the electricity statistics
- 5 Current with RMS value
Update regularly
- 6 Active power with RMS value²⁾;
Update regularly
- 7 Voltage with RMS value
Update regularly
- 8 Balance value
Update regularly per 0.05 kW.h
- 9 Total reverse active energy
It is excluded for balance calculation
- 10 Charge menu for charge setting
- 11 Setting menu for alarm setting

1) Following functionality could be checked at device information menu:

Tap-to-Run and Automation checking for scene setting.

Share Device to other users.

Remove device.

2) It will show the absolute value of active power if negative power is generated.

Enable the Negative-Active-Power alarm to check the wiring for right installation if necessary.

SPM01

Smart Energy Sensor / Monitor with Wireless-communication for 1P+N System

User interface example – setting page (Smart Life APP)

The image shows two screenshots from the Smart Life APP. The first screenshot is the 'Setting' page, and the second is the 'High-Power alarm' settings page. Red circles are overlaid on the screenshots to highlight specific UI elements, which are then described in the adjacent text.

UI Element	Description
12	Alarm records Click to view the alarm records.
13	High power alarm Click to set the threshold value
14	Abnormal temperature alarm Slide left/right to disable/enable the alarm
15	Over current alarm Click to set the threshold value
16	Over voltage alarm Click to set the threshold value
17	Under voltage alarm Click to set the threshold value
18	Negative active power alarm Slide left/right to disable/enable the alarm
19	Insufficient balance alarm Click to set the threshold value
20	Arrearage alarm Slide left/right to disable/enable the alarm
21	Threshold value range
22	Current set value for threshold
23	Slide switch Slide to left to disable the alarm Slide to right to enable the alarm

SPM01

Smart Energy Sensor / Monitor with Wireless-communication for 1P+N System

Alarm threshold values:

High power alarm	Usable alarm threshold value: 1 ~ 25 kW
Abnormal temperature alarm	To be triggered by temperature sensor inside
Over current alarm	Usable alarm threshold value: 10 ~ 100 A
Over voltage alarm	Usable alarm threshold value: 100 ~ 270 V
Under voltage alarm	Usable alarm threshold value: 90 ~ 250 V
Negative active power alarm	To be triggered when negative active power is more than 3 watts.
Insufficient balance alarm	Usable alarm threshold value: 10 ~ 500 kW.h
Arrearage alarm	To be triggered when balance is zero

SPM01

Smart Energy Sensor / Monitor with Wireless-communication for 1P+N System

User interface example – Statistics page (Smart Life APP)

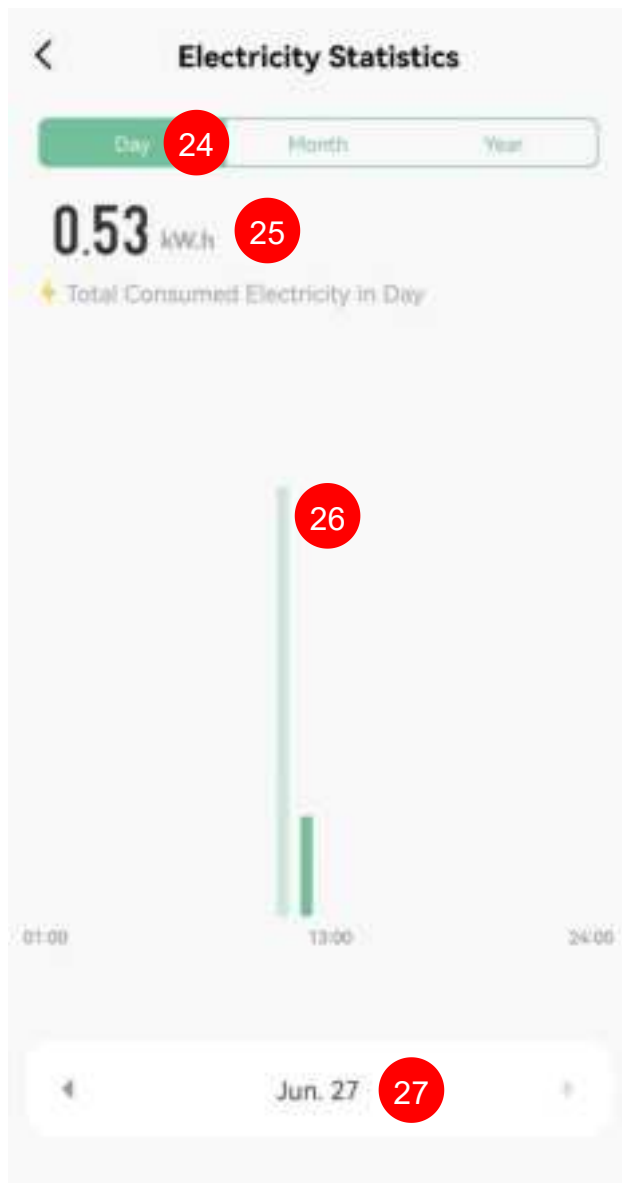

- 24 Electricity Statistics
Click Day / Month / Year to view:
Daily energy consumption chart
Monthly energy consumption chart
Yearly energy consumption chart
- 25 Total consumed electricity value
It could be checked with:
Total consumed energy in selected day
Total consumed energy in selected month
Total consumed energy in selected year
- 26 Chart
Value is displayed for the selected one.
Data within one year could be checked.

Daily energy consumption at each hour.
Monthly energy consumption at each day
Yearly energy consumption at each month
- 27 Timeline
Selected timeline for chart generation

SPM01

Smart Energy Sensor / Monitor with Wireless-communication for 1P+N System

User interface example – Charge page (Smart Life APP)

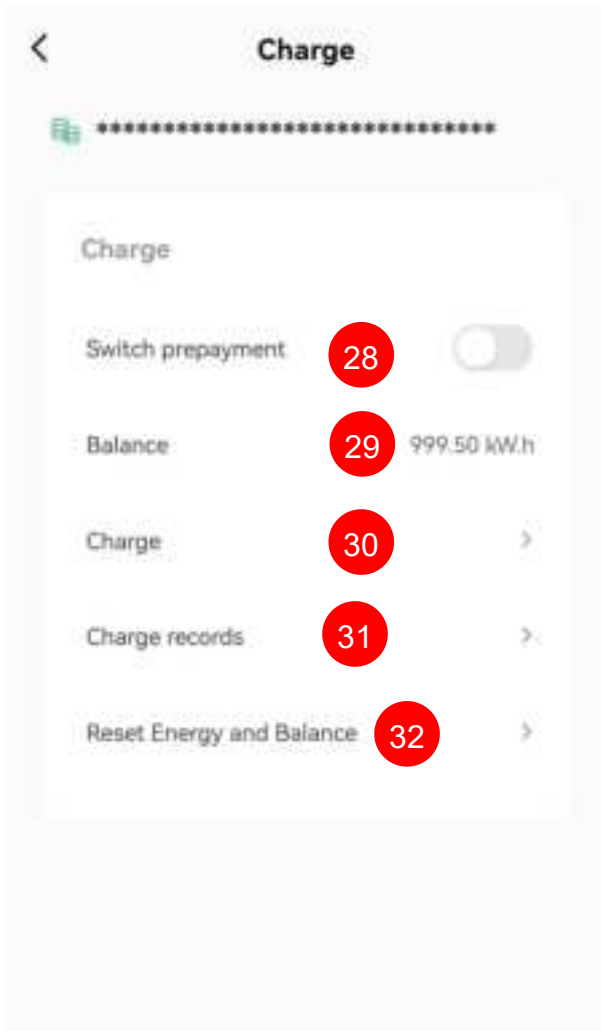

- 28 Switch prepayment
Not open for current version
To be open later
- 29 Balance
Current balance value
Update regularly
- 30 Charge
Click to charge the energy
Unit: kW.h
Balance value will be updated when charge action is done successfully.
- 31 Charge records
Click to view the charge records
- 32 Reset Energy and Balance
Zero or clear the following data:
 - Balance
 - Total forward active energy
 - Total reverse active energy
 - Daily consumed energy data
 - Monthly consumed energy data
 - Yearly consumed energy data

Remark:

Access could be set in Smart Life APP for different user when the device is shared to others for data safety consideration. Common users could not do the following action:

- Charge energy
- Check the threshold value for alarm
- Change the threshold value for alarm
- Enable or disable the alarm
- Reset energy and balance

It is only opened to the Administrator user.

SPM01

Smart Energy Sensor / Monitor with Wireless-communication for 1P+N System

Disclaimer:

The information in this document is subject to change without notice and should not be construed as a commitment by BITUOTECHNIK. BITUOTECHNIK assumes no responsibility for any errors that may appear in this document.

In no event shall BITUOTECHNIK be liable for direct, indirect, special, incidental or consequential damages of any nature or kind arising from the use of this document, nor shall BITUOTECHNIK be liable for incidental or consequential damages arising from use of any software or hardware described in this document.

Trademarks

BITUOTECHNIK is a registered trademark of Shanghai Bituo Electric Co.,Ltd.

Shanghai Bituo Electric Co.,Ltd.

Address: 8F, Building 6, Qianfan Rd. 288, Songjiang District, Shanghai 201600, China

Tel: +86 (21) 5780 8599

Email: info@bituo-technik.com

Website : www.bituo-technik.com

